

LUX

LUX	P935009 00001
LUX B	P935010 00001
LUX 2B	P935011 00001
LUX FC2B	P935039 00001
LUX L	P935012 00001
LUX G	P935013 00001
LUX R2BSN2	P935046 00002

- LUX: this **hydraulic operator with a compact line**, is manufactured in different versions to automate gates having leaf lengths from 1.8 to 5 metres.
- Either provided with a **hydraulic lock**, which can hold the gate closed or opened, or reversible (with the use of an electric lock).
- **Antisquash safety** guaranteed by two by-pass valves which regulate the force on opening and on closing.
- Some versions are provided with a **slow-down device**.



Recommended control panel:
ALCOR SD

Rev. operators	LUX	LUX L	LUX G
Single-phase power supply	230V~ ± 10%, 50 Hz	230V~ ± 10%, 50 Hz	230V~ ± 10%, 50 Hz
Absorbed power	250W	250W	250W
Thermal protection	integrated	integrated	integrated
Max leaf weight (N)	3000	from 3000 to 5000	8000
(kg)	-300	from 300 to 500	800
Max leaf length	2 m	from 4 to 2 m	from 5 to 2 m
Rod working stroke (mm)	270	270	390
Rod speed (mm/sec)	14	8,3	8,3
Opening or closing time	17 s	34 s	50 s
Slow down	-	-	-
Impact reaction	hydraulic clutch	hydraulic clutch	hydraulic clutch
Type of lock	electric lock	electric lock	electric lock
Manual manoeuvre	reversible	reversible	reversible
N° manoeuvres in 24 hours	500	350	250
Environmental conditions	from -10°C to +60°	from -10°C to +60°	from -10°C to +60°
Degree of protection	IP 55	IP 55	IP 55
Operator weight	87N (-8,7kg)	87N (-8,7kg)	112N (-11,2kg)
Dimensions	see drawing	see drawing	see drawing

Irrever. operators	LUX B	LUX 2B	LUX R2BSN2	LUX FC2B
Single-phase power supply	230V~ ± 10%, 50 Hz	230V~ ± 10%, 50 Hz	230V~ ± 10%, 50 Hz	230V~ ± 10%, 50 Hz
Absorbed power	250W	250W	250W	250W
Thermal protection	integrated	integrated	integrated	integrated
Max leaf weight	3000N (-300kg)	3000N (-300kg)	3000N (-300kg)	3000N (-300kg)
Max leaf length	2 m	2 m	2 m	2 m
Rod working stroke (mm)	270	270	250	280+spring compr.
Rod speed (mm/sec)	14	14	14	14
Opening or closing time	17s	17s	16s+slow down	18s
Slow down	-	-	closing	-
Impact reaction	hydraulic clutch	hydraulic clutch	hydraulic clutch	hydraulic clutch
Type of lock	hydraulic closing	hydraulic clos./open.	hydraulic clos./open	hydraulic clos./open
Manual manoeuvre	release key	release key	release key	release key
N° manoeuvres in 24 hours	500	500	500	500
Environmental conditions	from -10°C to +60°	from -10°C to +60°	from -10°C to +60°	from -10°C to +60°
Degree of protection	IP 55	IP 55	IP 55	IP 55
Operator weight	87 N (-8,7kg)	87 N (-8,7kg)	87 N (-8,7kg)	87 N (-8,7kg)
Dimensions	see drawing	see drawing	see drawing	see drawing

Hydraulic operator for swing gates, leaf length up to 5 m, weight up to 800 kg, residential and apartment-block use

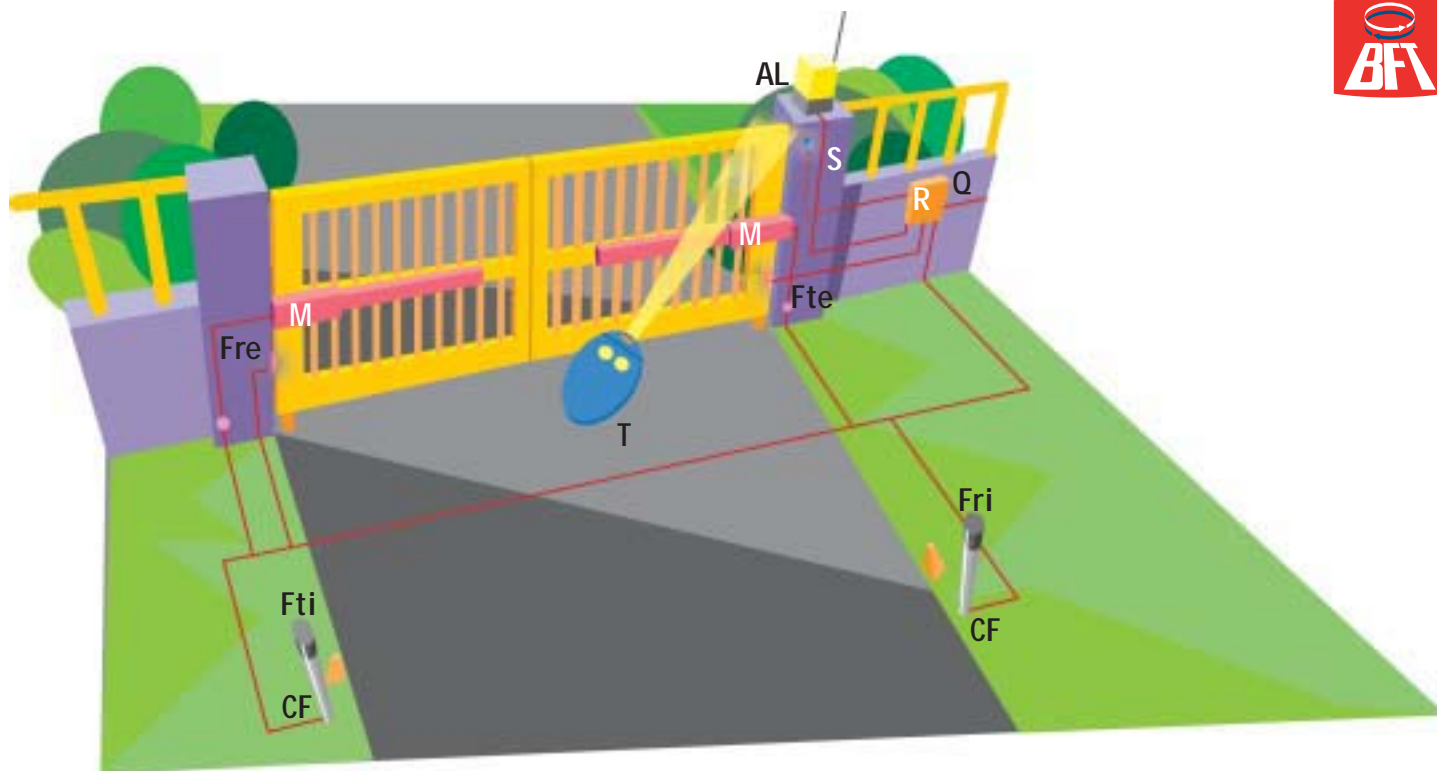

Example of installation

- M hydraulic operator with lock, LUX B
- Q control panel ALCOR SD
- R single-channel rolling-code receiver, suitable for Mitto transmitter
- T double-channel rolling-code transmitter, Mitto 2 12V
- Ftx-Frx Pair of photocells, Cellula130
- CF Pair of posts, CC130
- AL blinker with antenna
- S key selecto, Intro

• For system layout and installation conditions, refer to the standards and laws in force in the country of installation.

Dimensions

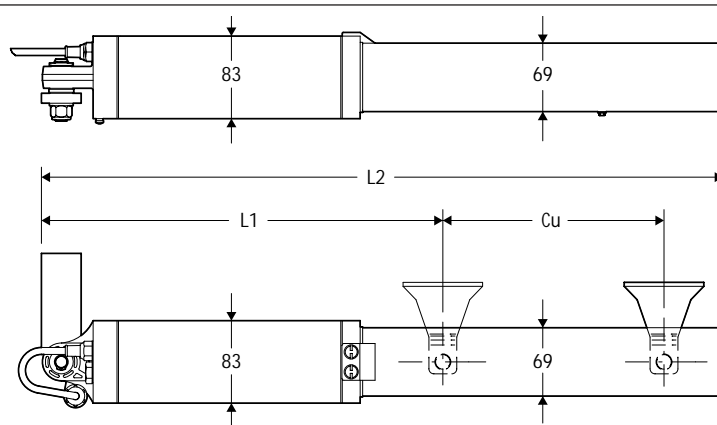

Dimensions

Model	L1	Cu	L2
LUX	715 mm	270 mm	1025 mm
LUX R	710 mm	250 mm	1050 mm
LUX G	850 mm	390 mm	1300 mm
LUX FC	850 mm	280 mm	1320 mm

Main characteristics

Hydraulic operator for the automation of swing leaf gates for residential and apartment-block use • hydraulic force limiter • recommended control panel: ALCOR SD • Main specifications: supply 230V ± 10% 50Hz • power 250W • rod speed from 14mm/sec to 8.3mm/sec • rod stroke from 250mm to 390mm • maximum torque 3000Nm • max leaf weight 3000N (~300 kg) • max leaf length 5000mm • Models available: LUX, LUX L, LUX G (reversible) • LUX B, LUX 2B, LUX 2B FC (irreversible) • LUX R2BSN2 (slowed down, reversible and irreversible)